

MAKE	MODEL	YEAR	INSTALL	PTS	LIGHTS	STARTER	DCM	I/O CHANGES
DL-TL7 Toyota	Camry PTS AT	2018-21	Type 1	Optional	Park / Auto Type 1	No	No	Green White/Blue n/a

This installation requires **BLADE-AL(DL)-TL7** firmware, flash module and update controller before beginning the installation.

Install Type 1: Main Body ECU (driver side kick panel), steering lock connector, no DCM interface required.

Page. 2: Version 1 harness, yellow starter wire (no connection)

Page. 3: Version 2 harness, green/white starter/parking light wire (no connection), white/red & white/black (no connection)

Lights: Parking light and auto-light control are handled using the pre-terminated **green/white** wire bundled with the BLADE connector. Remove the (-) pk light wire from the controller's gray I/O connector and replace with the one specified, for status and diagnostic reporting. Connect to the headlight switch connector [B] as illustrated.

Locks: This installation type requires additional connections to the vehicle door locks to ensure proper synchronization with the OEM remotes. **The 6-pin lock connector is required for correct operation.** Connect to the control module lock output port.

Blue/Yellow (PTS): The PTS wire (blue/yellow) is optional. If Idle Mode is not desired, trim as necessary, then insulate and secure.

Idle Mode is not a supported feature of the FTI-TLP2 Harness: The Idle Mode feature which allows the user to exit a running has been excluded from the FTI-TLP2 harness wiring. If this feature is desired, please refer to the full BLADE installation diagram for the applicable wiring and make the required connection to the vehicle PTS button.

TAKEOVER NOT SUPPORTED: THE VEHICLE WILL SHUT DOWN UPON OPENING DRIVER'S DOOR

FTI-TLP2: Installation and Configuration Notes

- A CONNECTIONS REQUIRED**
- B CONNECTIONS REQUIRED**
- C OPTIONAL CONNECTION**
- D NOT REQUIRED**



FEATURE COVERAGE																							
IMMOBILIZER DATA	3X LOCK REM START	PTS CONTROL	ARM OEM ALARM	DISARM OEM ALARM	A/M ALARM CTRL FROM OEM REMOTE	A/M RS CONTROL FROM OEM REMOTE	PRIORITY UNLOCK	DOOR LOCK	DOOR UNLOCK	TRUNK/HATCH RELEASE	DOOR STATUS OUT	TRUNK STATUS OUT	TACHOMETER OUT	BRAKE STATUS OUT	E-BRAKE STATUS	PARKING LIGHTS	AUTOLIGHT CONTROL						

- FT-DAS Required for manual transmission.
- BOTH Red & Red/White MUST be connected with high current application.

Jumper Setting

CM7000/7200

CM-900S/900AS

CM900AS/900S Jumper

Cut loop for A/T

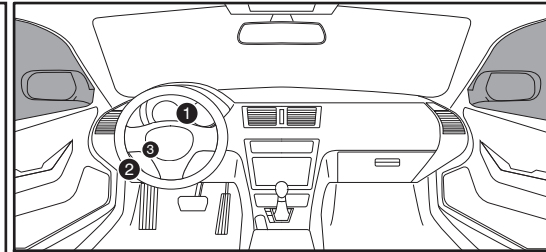
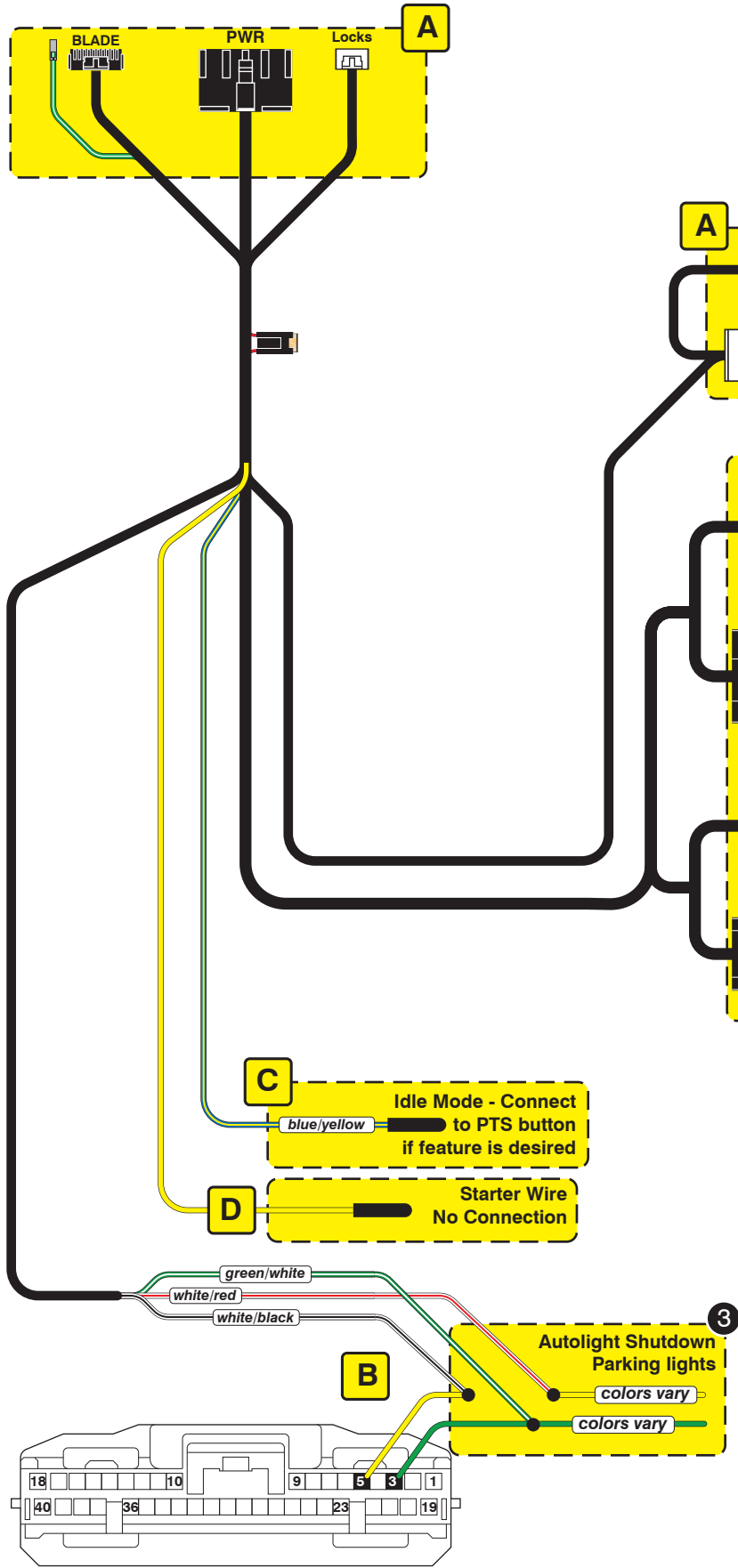

Steering Lock Connector



Main Body ECU

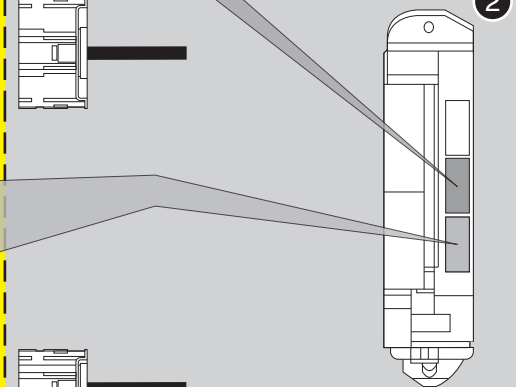

LED Programming Error Codes

Module LED flashing RED during programming

- 1x - CAN error, confirm harness configuration
- 2x - No IGN, confirm IGN power and harness configuration
- 3x - IMMO/CAN error, confirm harness configuration
- 4x - No VIN, module may default to base platform #2
- 5x - Unknown VIN, module may default to base platform #2
- 6x - OEM starter detected, cycle IGN, if issue persists, remove and reprogram

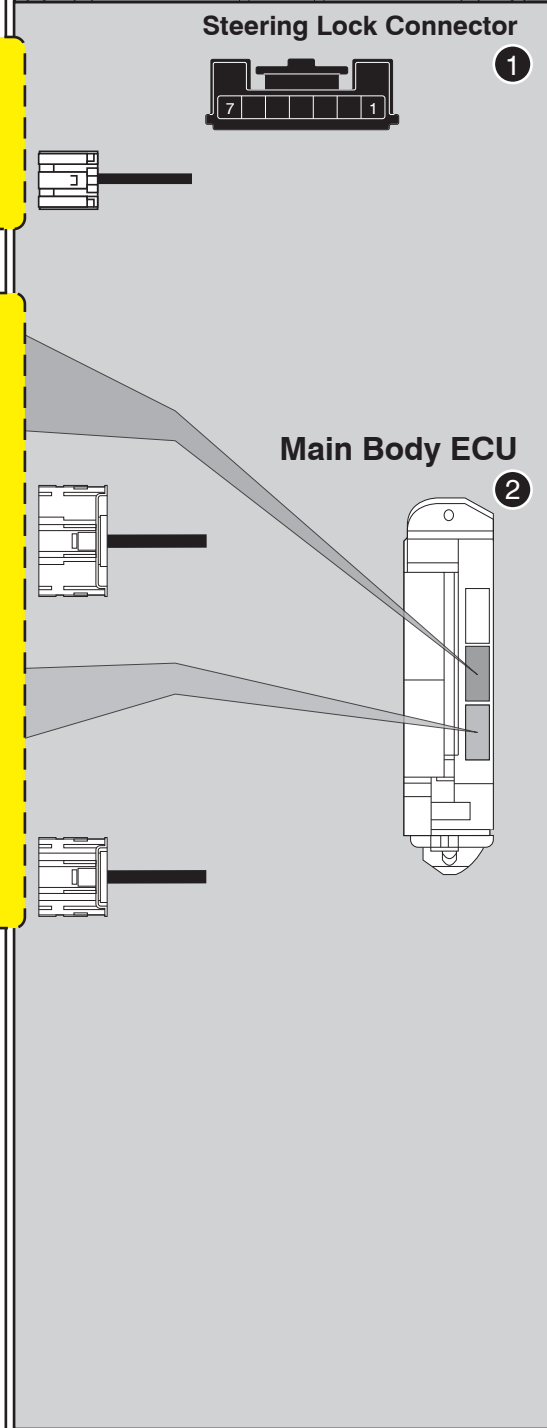
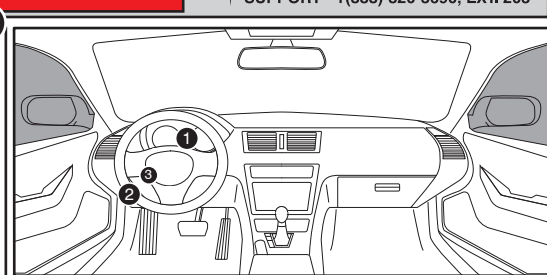
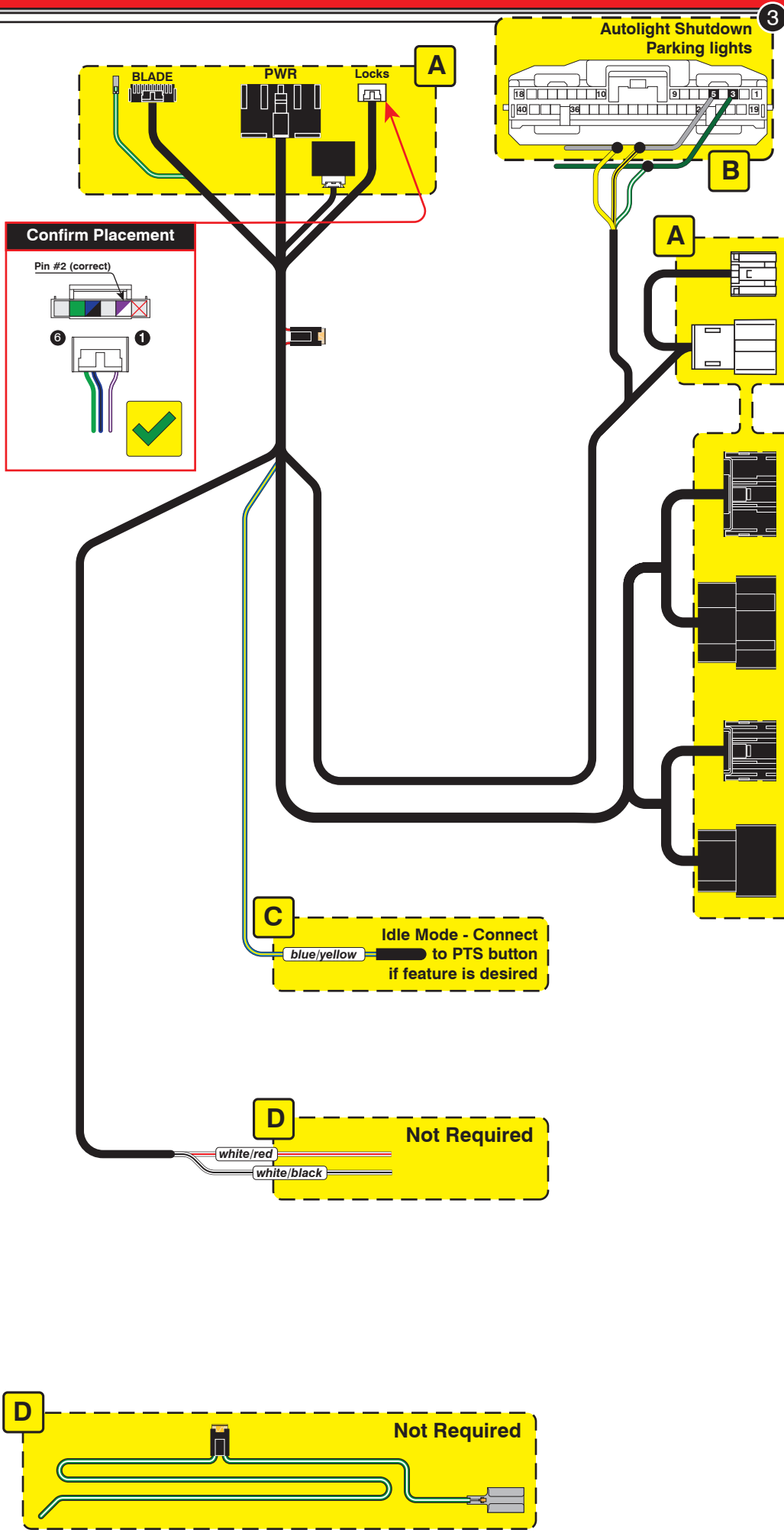

LED Programming Error Codes

Module LED flashing RED during programming

- 1x - CAN error, confirm harness configuration
- 2x - No IGN, confirm IGN power and harness configuration
- 3x - IMMO/CAN error, confirm harness configuration
- 4x - No VIN, module may default to base platform #2
- 5x - Unknown VIN, module may default to base platform #2
- 6x - OEM starter detected, cycle IGN, if issue persists, remove and reprogram

CARTRIDGE INSTALLATION

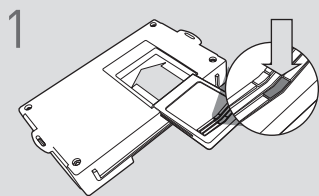

1 Slide cartridge into unit. Notice button under LED.

2

Ready for Module Programming Procedure.

MODULE PROGRAMMING PROCEDURE

NOTE

I IMPORTANT: The hood must be closed.



1 Push start button twice [2x] to ON position.

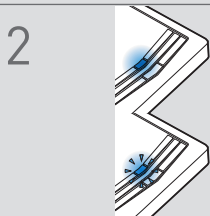

2 Wait, if LED turns solid BLUE for 2 seconds, proceed to step 7.

If LED flashes BLUE rapidly, proceed to step 3.



3 Push start button once [1x] to OFF position.

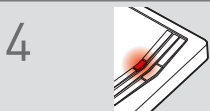

4 Wait, LED will turn solid RED. (This may take up to 5 minutes.)



5 Push start button twice [2x] to ON position.



6 Wait, LED will turn solid BLUE for 2 seconds.



7 Push start button once [1x] to OFF position.

8

Module Programming Procedure completed.