

FTI-TLK2: Vehicle Coverage and Preparation Notes

Make	Model	Year	Install	CAN	Lights	IMI/IMO	TPMS	I/O Changes
DL-TL10 Toyota	Corolla STD Key (H) AT	2020-22	Type 3	ECU	Park / Auto DATA	PKP 18-Pin	DKP (2) Lt.Blue	Green White/Blue N/A

This install requires **BLADE-AL(DL)-TL10** firmware, flash module and update the controller before beginning the installation.

CAN: CAN data connections are handled through connections at the ECU, no other connections are required.

IMI/IMO (immobilizer): Immobilizer is gathered using the 18-pin ECU adapter, no additional connections are required.

TPMS Ignition: The TPMS ignition wire, located in the driver's kick panel, must be interrupted if the 3X Lock control is required. If the feature is not required, and aftermarket remotes are being used, no connection is necessary.

Parking Lights: TL10 firmware handles parking lights through data, if issues arise the +parking light (green/white) can be used.

Keysense & RAP: The TLK2 harness includes pre-terminated connections for Keysense and RAP circuits.
Keysense (brown/white) is only required in manual transmission applications, insert CM I/O connector keysense position.
RAP (orange) connects to the driver door circuit, insert in any POC position and configure for RAP in the feature options.

Included ORG/BLK: The TLK2 kit includes an additional wire intended for SIL connections in TL9 applications, it is not required for this installation.

I/O Changes: No changes are required.



FTI-TLK2: Installation and Configuration Notes

- A CONNECTIONS REQUIRED**
- B CONNECTION REQUIRED**
- C CONNECTION REQUIRED**
- D OPTIONAL CONNECTION**
- E OPTIONAL CONNECTION**

* available only when ignition is off
 ** if equipped with factory hood pin switch



FEATURE COVERAGE																						
IMMOBILIZER DATA	PRIORITY UNLOCK	ARM OEM ALARM	DISARM OEM ALARM	DOOR LOCK	DOOR UNLOCK	PARKING LIGHT CONTROL	POWER LIFTGATE	TRUNK/HATCH RELEASE*	DOOR STATUS	TRUNK STATUS	HOOD STATUS **	TACH OUTPUT	BRAKE STATUS	E-BRAKE STATUS	A/M ALARM CTRL FROM OEM REMOTE	A/M RS CONTROL FROM OEM REMOTE						

•FT-DAS Required for manual transmission.
•BOTH Red & Red/White MUST be connected with high current application.

Jumper Setting

CM7000/7200 **Cut loop for A/T**

CM900AS/900S Jumper

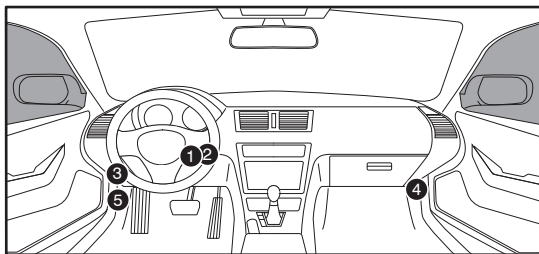
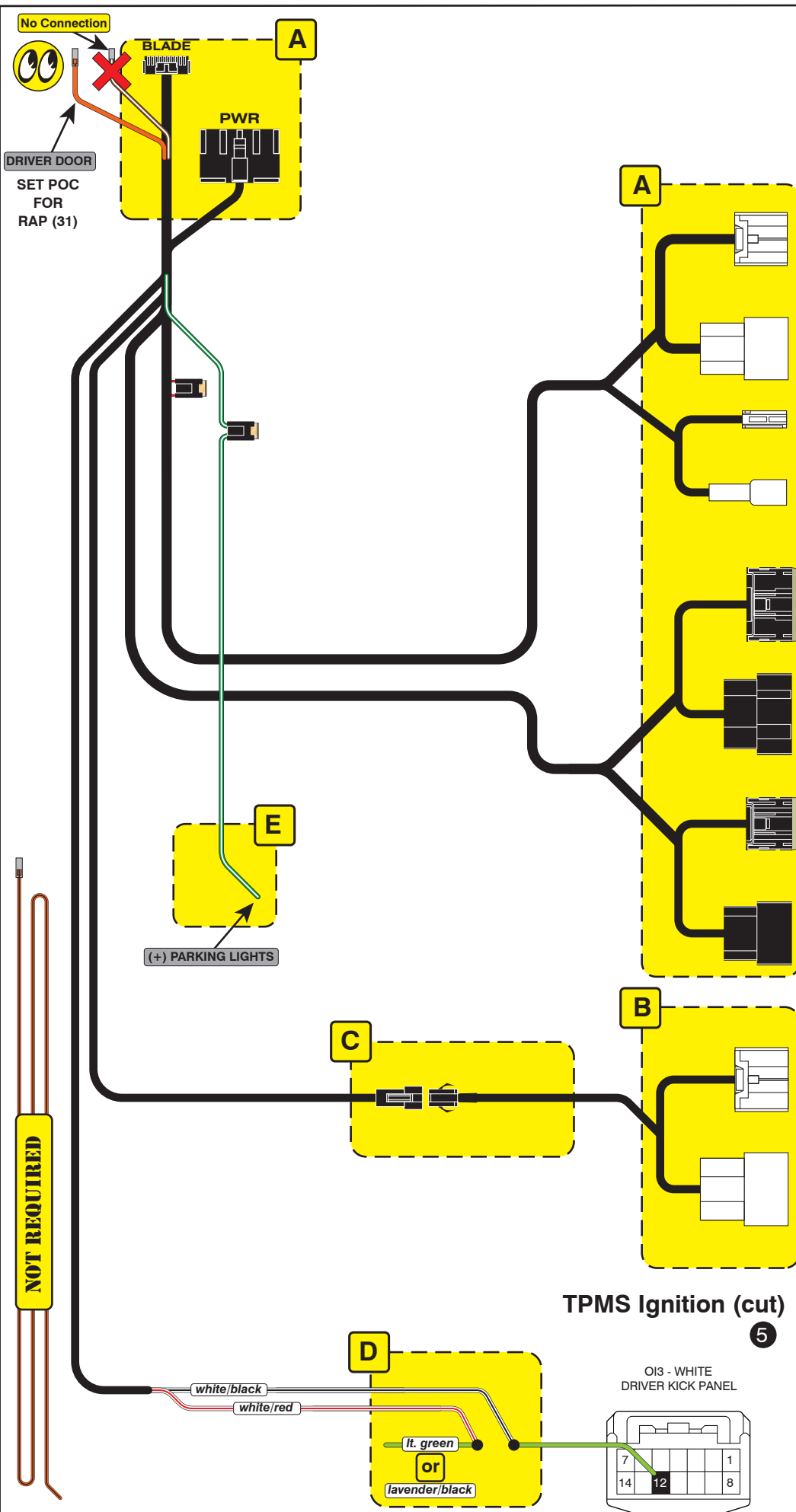

Ignition Connector 1

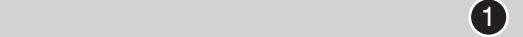

Keysense 2

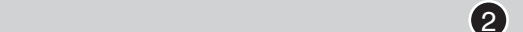

Main Body ECU 3

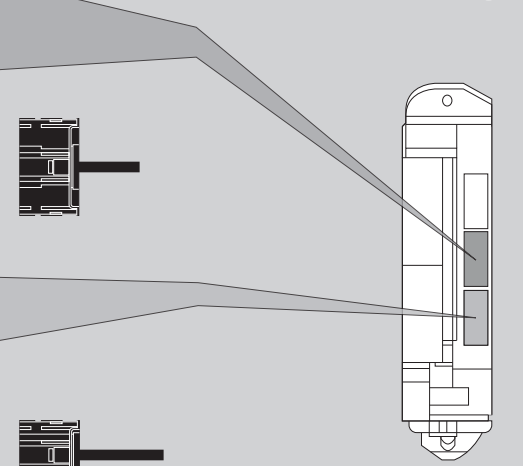
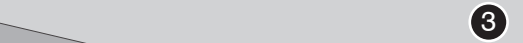

Junction Connector (IMI/IMO) 4

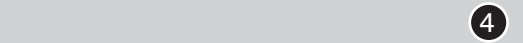

PASSENGER KICK PANEL GRAY

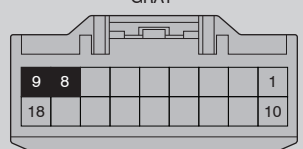

TL10 LED Programming Error Codes

Module LED flashing RED during programming

- 1x - No CAN activity, check harness connections.
- 2x - No analog Ignition, check harness connections.
- 3x - VIN received but not in table, contact iDataLink.
- 4x - No Immobilizer data (IMI), check adapter configuration.
- 5x - No Immobilizer data (IMO), check adapter configuration.
- 6x - Problem with Klon log, retry programming from step 1.
- 7x - CryptKey doesn't match, reflash and redo Klon.

CARTRIDGE INSTALLATION

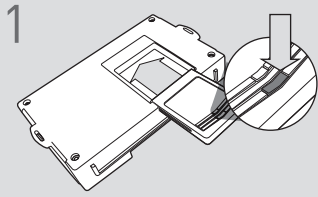

1 Slide cartridge into unit. Notice button under LED.

2

Ready for Module Programming Procedure.

MODULE PROGRAMMING PROCEDURE

NOTE

! IMPORTANT: The hood must be closed.

1 OFF ACC **ON** START

Set ignition to ON position.



2

Wait, LED will turn solid RED to confirm that the ignition is ON.

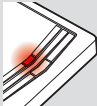

3

Wait, LED will flash BLUE rapidly.



4 OFF ACC ON START

Set ignition to OFF position.

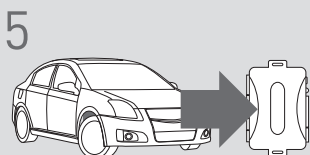

5 **WARNING:**
Disconnect power last.
Disconnect module from vehicle.

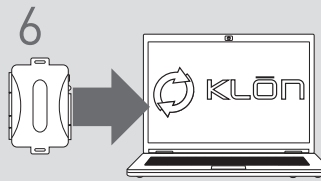

6 Connect module to computer and proceed with extended programming.

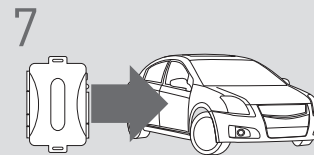

7 **WARNING:**
Connect power first.
Connect module to vehicle.

8 OFF ACC **ON** START

Set ignition to ON position.

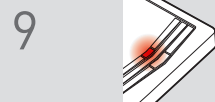

9 Wait, LED will turn solid RED to confirm that the ignition is ON.



10 Wait, LED will turn solid BLUE for 2 seconds.

11 OFF ACC ON START

Set ignition to OFF position.



12

Module Programming Procedure completed.