

Make	Model	Year	Install	BCM	Lights	Locks	POC 1	I/O Changes
DL-NI4 Nissan	Versa Intelli-Key AT	2007-11	Type 3	LSC	Park / Auto NI-LOCK	DATA	Hazard1/2	Green White/Blue

Intstall **Type 1** requires **BLADE-AL(DL)-NI4**, flash module and update the controller firmware before beginning the installation.

I/O Changes: Each vehicle in this installation group have different configuration requirements for proper handling of ACC and START circuit handling. Please ensure that the appropriate changes have been made before testing. **The required changes are listed below.**

Intelli-Key Wiring: Additional wiring and relay are required. See page 3 of this document for additional location and interface requirements.

CM900S/900AS I/O Changes:

Optional Hazard Light Control:

NI-LOCK harness **green/white** is pre-wired for hazards, connect harness wire to the controller POC1 (**green/white**), additional configuration required. Vehicles equipped with a **MOMENTARY** activation switch require that POC1 be configured for **Hazard light** (POC option #30), if the switch is **LATCHING** type you will use **Hazard light 2** (POC option #23).

Auto-Light OFF:

NI-LOCK harness **orange** is pre-wired for Auto-light shut off, if the vehicle is equipped with auto-lights connect CM REARM output (**orange**) to **orange** wire in harness.

D **NI-LOCK harness configuration:** Configure Double Pulse Unlock (**feature 1-04, option 2**) Vehicle lock functions are handled through data, additional harness configuration is not required.

FTI-NSK1: Installation and Configuration Notes

- A** CUTS REQUIRED - INSULATE AFTER CUTTING
- B** REQUIRED CONNECTION - USE JUMPER IF NO IMMOBILIZER
- C** CONNECT AS ILLUSTRATED
- D** CONNECT AS ILLUSTRATED
- E** CONNECT AS ILLUSTRATED



FEATURE COVERAGE																		
IMMOBILIZER DATA	PRIORITY UNLOCK	DOOR LOCK	DOOR UNLOCK	ARM OEM ALARM	DISARM OEM ALARM	TRUNK/HATCH RELEASE	A/M ALARM CTRL	A/M RS CONTROL	HOOD STATUS	DOOR STATUS	TRUNK STATUS	RAP SHUTDOWN	BRAKE STATUS	E-BRAKE STATUS	TACH OUTPUT	SECURE TAKEOVER	PARKING LIGHTS	HAZARD LIGHTS

•FT-DAS Required for manual transmission.
•BOTH Red & Red/White MUST be connected with high current application.

Jumper Setting

CM7000/7200 **CM-900S/900AS**

CM900AS/900S Jumper

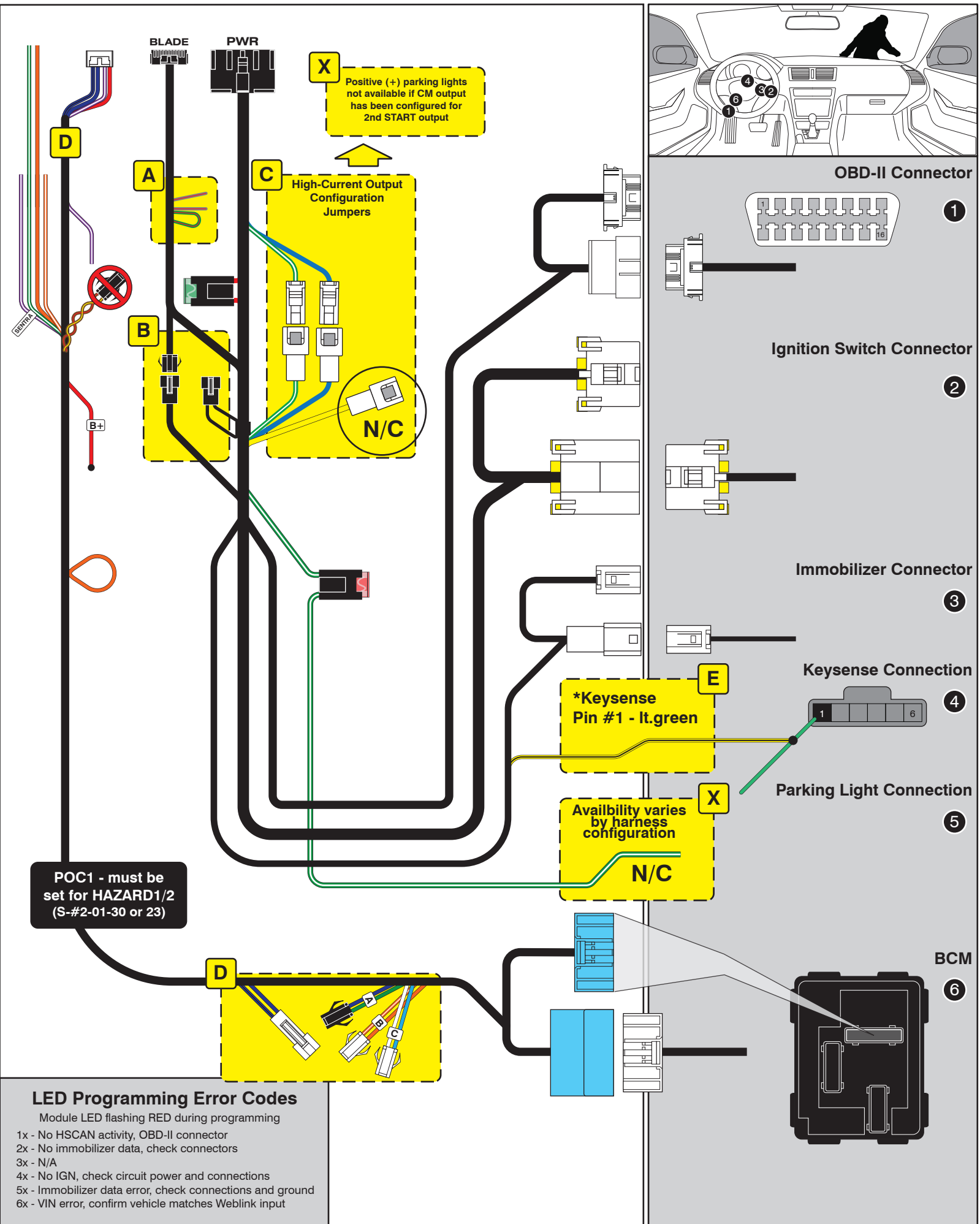

X
Positive (+) parking lights not available if CM output has been configured for 2nd START output

C
High-Current Output Configuration Jumpers

N/C

E
*Keysense Pin #1 - Lt. green

X
Availability varies by harness configuration
N/C

POC1 - must be set for HAZARD1/2 (S-#2-01-30 or 23)

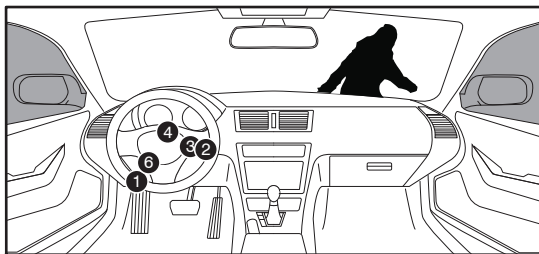
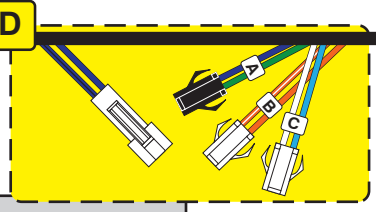

OBD-II Connector

1

Ignition Switch Connector

2

Immobilizer Connector

3

Keysense Connection

4

Parking Light Connection

5

BCM

6

LED Programming Error Codes

- Module LED flashing RED during programming
- 1x - No HSCAN activity, OBD-II connector
 - 2x - No immobilizer data, check connectors
 - 3x - N/A
 - 4x - No IGN, check circuit power and connections
 - 5x - Immobilizer data error, check connections and ground
 - 6x - VIN error, confirm vehicle matches Weblink input

FTI-NSK1-NI4 Type 3: Supplemental Intelli-Key Wiring Diagram

A Connector illustrations depict the wire-side view of the connector at the Intelli-Key module, position is accurate to this view.

B FT-RLY-10A is a compact, pre-wired relay accessory, wire as illustrated if available. If you are using a standard Bosch type relay, the illustrations utilize consistent color coding for the required connections.

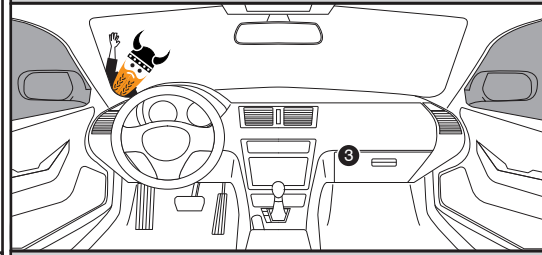

Make	Model	Year	Intelli-Key Module Location
Nissan	Versa Intelli-Key	2007-11	(3) Behind glove box, left Pin #6 - yellow

*Tic-Tac-Toe

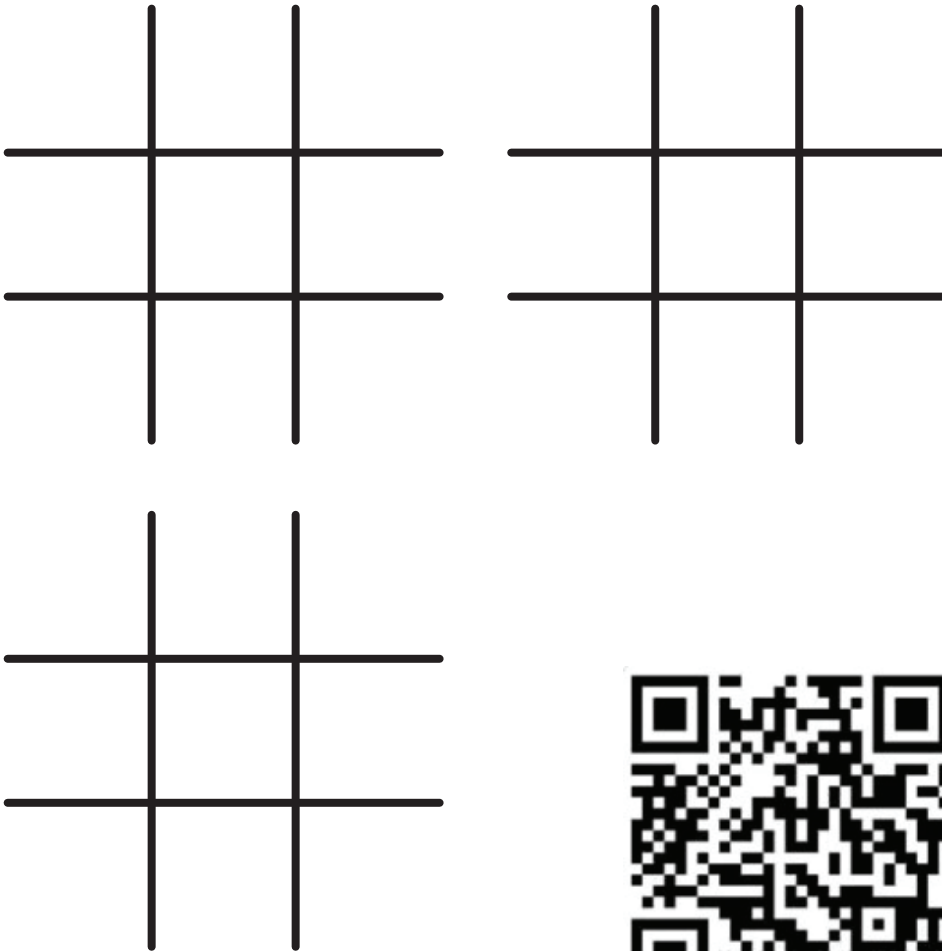

A Intelli-key Module 3

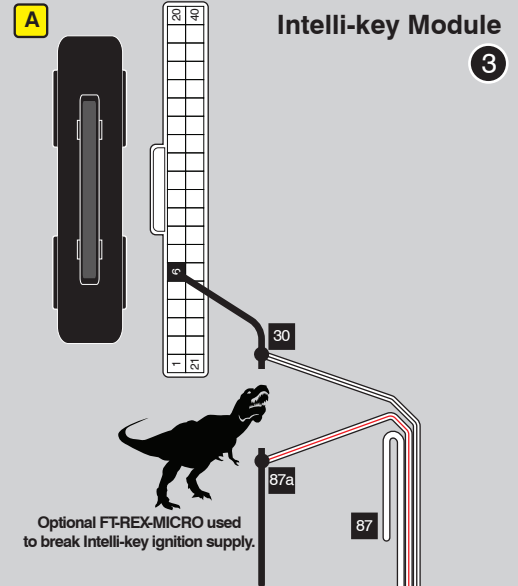

B FT-RLY-10A

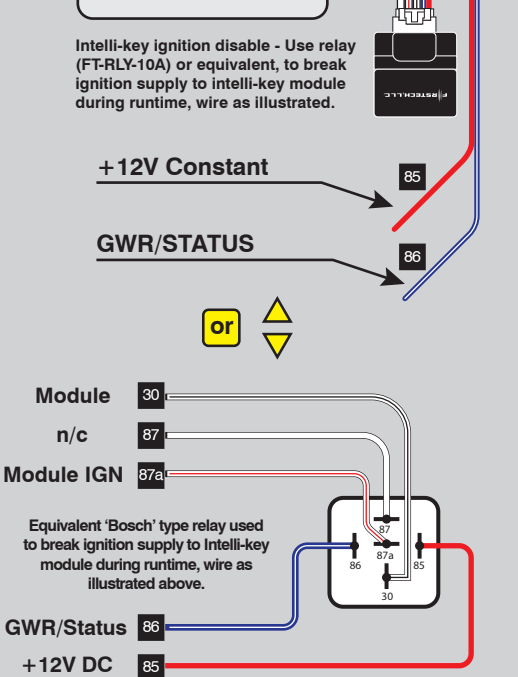

CARTRIDGE INSTALLATION

1

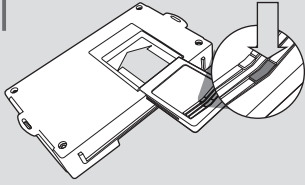

Slide cartridge into unit. Notice button under LED.

2

Ready for Module Programming Procedure.

MODULE PROGRAMMING PROCEDURE

NOTE

I To complete this procedure, use one regular key or one valet key.

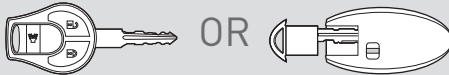

II When programming, all key fobs must be located at least 10 feet away from the vehicle.

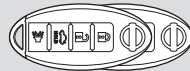

1

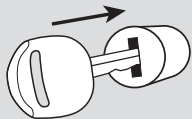

Insert key into ignition.

2

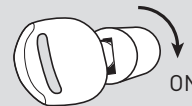

Turn key to ON position.

3

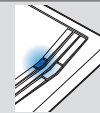

Wait, LED will turn solid BLUE for 2 seconds.

4

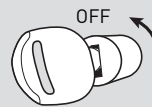

Turn key to OFF position.

5

Module Programming Procedure completed.