

Make	Model	Year	Install	BCM	Lights	Locks	POC 1	I/O Changes
DL-NI4 Nissan	Maxima Intelli-Key AT	2007-08	Type 3	LSC	Park / Auto NI-LOCK	DATA	Hazard1/2	Green White/Blue START2

Intstall **Type 1** requires **BLADE-AL(DL)-NI4**, flash module and update the controller firmware before beginning the installation.

**I/O Changes:** Each vehicle in this installation group have different configuration requirements for proper handling of ACC and START circuit handling. Please ensure that the appropriate changes have been made before testing. **The required changes are listed below.**

**Intelli-Key Wiring:** Additional wiring and relay are required. See page 3 of this document for additional location and interface requirements.

**CM900S/900AS I/O Changes:**

**START2:** Set feature option **1-6-2** (starter output 10A max), connect **green/white** to **yellow** (2nd START) at configuration point [C]

**Optional Hazard Light Control:**

**NI-LOCK** harness **green/white** is pre-wired for hazards, connect harness wire to the controller POC1 (**green/white**), additional configuration required. Vehicles equipped with a **MOMENTARY** activation switch require that POC1 be configured for **Hazard light** (POC option #30), if the switch is **LATCHING** type you will use **Hazard light 2** (POC option #23).

**Auto-Light OFF:**

**NI-LOCK** harness **orange** is pre-wired for Auto-light shut off, if the vehicle is equipped with auto-lights connect CM REARM output (**orange**) to **orange** wire in harness.

**D**

**NI-LOCK harness configuration:** Configure Double Pulse Unlock (**feature 1-04, option 2**) Vehicle lock functions are handled through data, additional harness configuration is not required.

**FTI-NSK1: Installation and Configuration Notes**

- A** CUTS REQUIRED - INSULATE AFTER CUTTING
- B** REQUIRED CONNECTION - USE JUMPER IF NO IMMOBILIZER
- C** CONNECT AS ILLUSTRATED
- D** CONNECT AS ILLUSTRATED
- E** CONNECT AS ILLUSTRATED



FEATURE COVERAGE																		
IMMOBILIZER DATA	PRIORITY UNLOCK	DOOR LOCK	DOOR UNLOCK	ARM OEM ALARM	DISARM OEM ALARM	TRUNK/HATCH RELEASE	A/M ALARM CTRL	A/M RS CONTROL	HOOD STATUS	DOOR STATUS	TRUNK STATUS	RAP SHUTDOWN	BRAKE STATUS	E-BRAKE STATUS	TACH OUTPUT	SECURE TAKEOVER	PARKING LIGHTS	HAZARD LIGHTS

•FT-DAS Required for manual transmission.  
•BOTH Red & Red/White MUST be connected with high current application.

**Jumper Setting**

**CM7000/7200** **Cut loop for A/T**

**CM-900S/900AS**

**CM900AS/900S Jumper**

**START**  
**ACC**  
**IGN1**

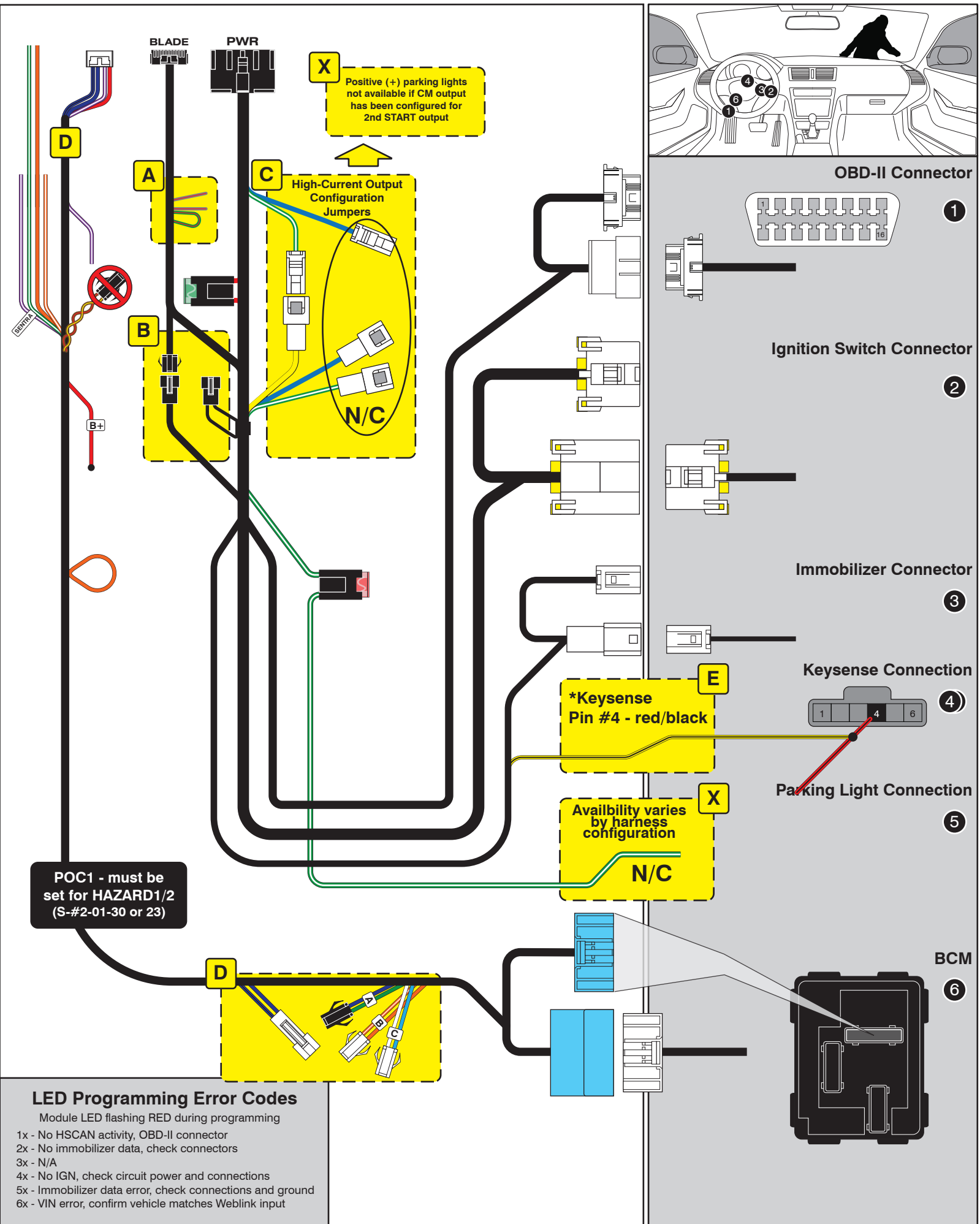

**X** Positive (+) parking lights not available if CM output has been configured for 2nd START output

**C** High-Current Output Configuration Jumpers  
N/C

**E** \*Keysense Pin #4 - red/black

**X** Availability varies by harness configuration  
N/C

**POC1 - must be set for HAZARD1/2 (S-#2-01-30 or 23)**

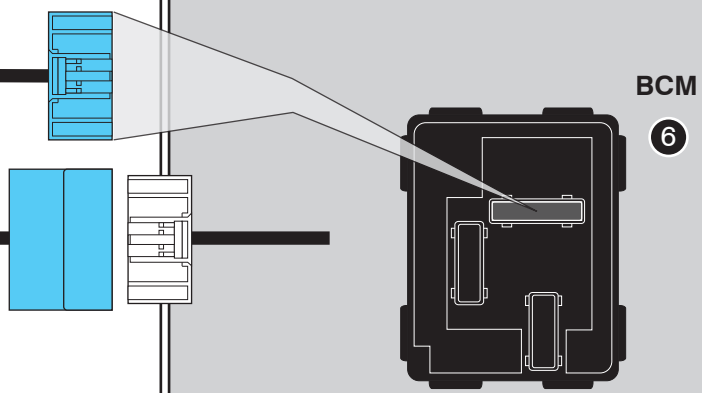
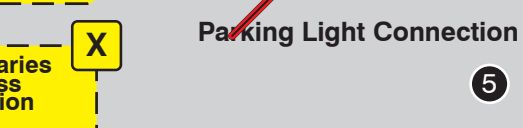
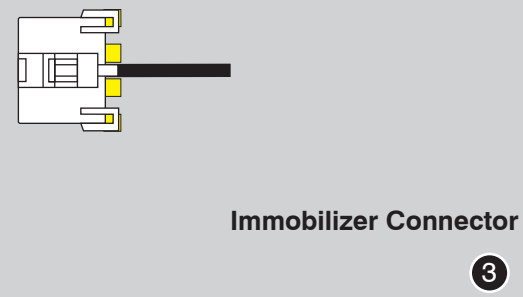
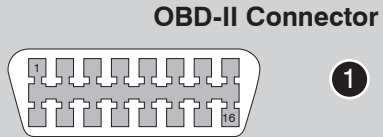
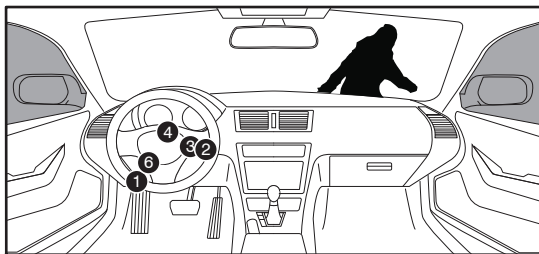
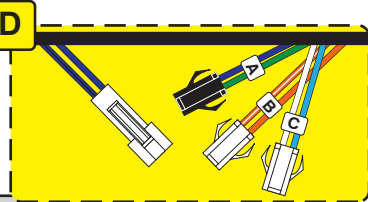

**LED Programming Error Codes**

Module LED flashing RED during programming

- 1x - No HSCAN activity, OBD-II connector
- 2x - No immobilizer data, check connectors
- 3x - N/A
- 4x - No IGN, check circuit power and connections
- 5x - Immobilizer data error, check connections and ground
- 6x - VIN error, confirm vehicle matches Weblink input

# FTI-NSK1-NI4 Type 3: Supplemental Intelli-Key Wiring Diagram

**A** Connector illustrations depict the wire-side view of the connector at the Intelli-Key module, position is accurate to this view.

**B** FT-RLY-10A is a compact, pre-wired relay accessory, wire as illustrated if available. If you are using a standard Bosch type relay, the illustrations utilize consistent color coding for the required connections.

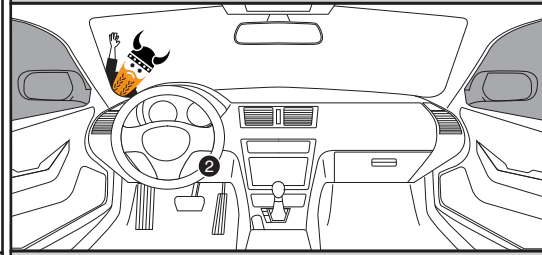

Make	Model	Year	Intelli-Key Module Location
Nissan	Maxima Intelli-Key	2007-08	(2) Above gas pedal, RSC Pin #6 - green

## \*Tic-Tac-Toe

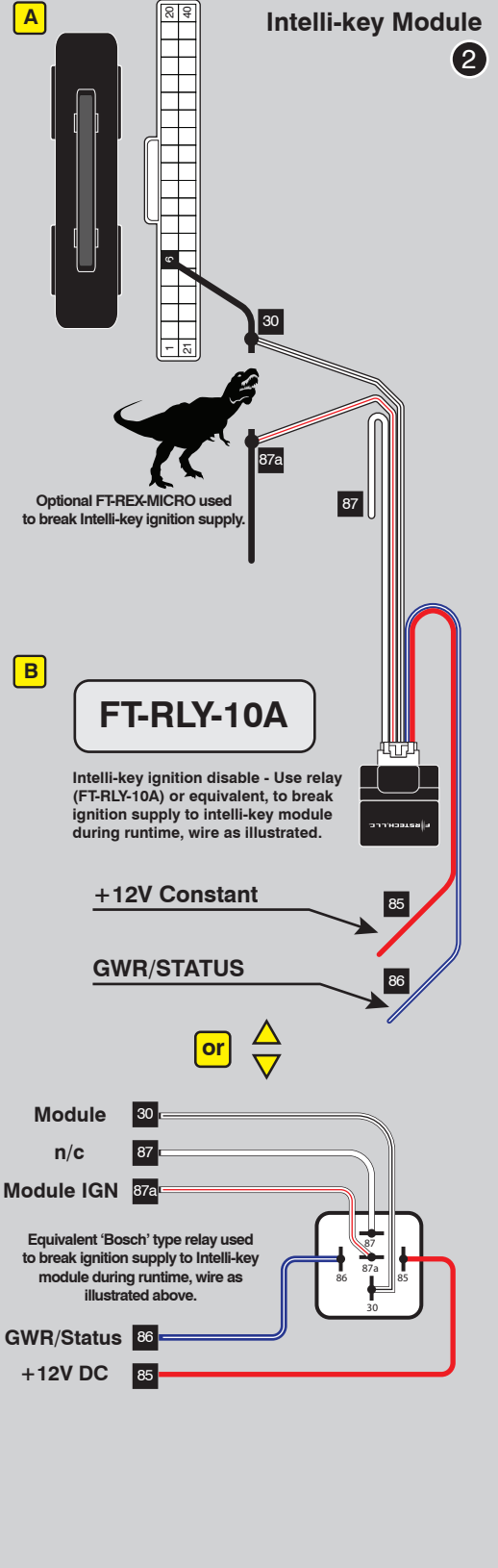
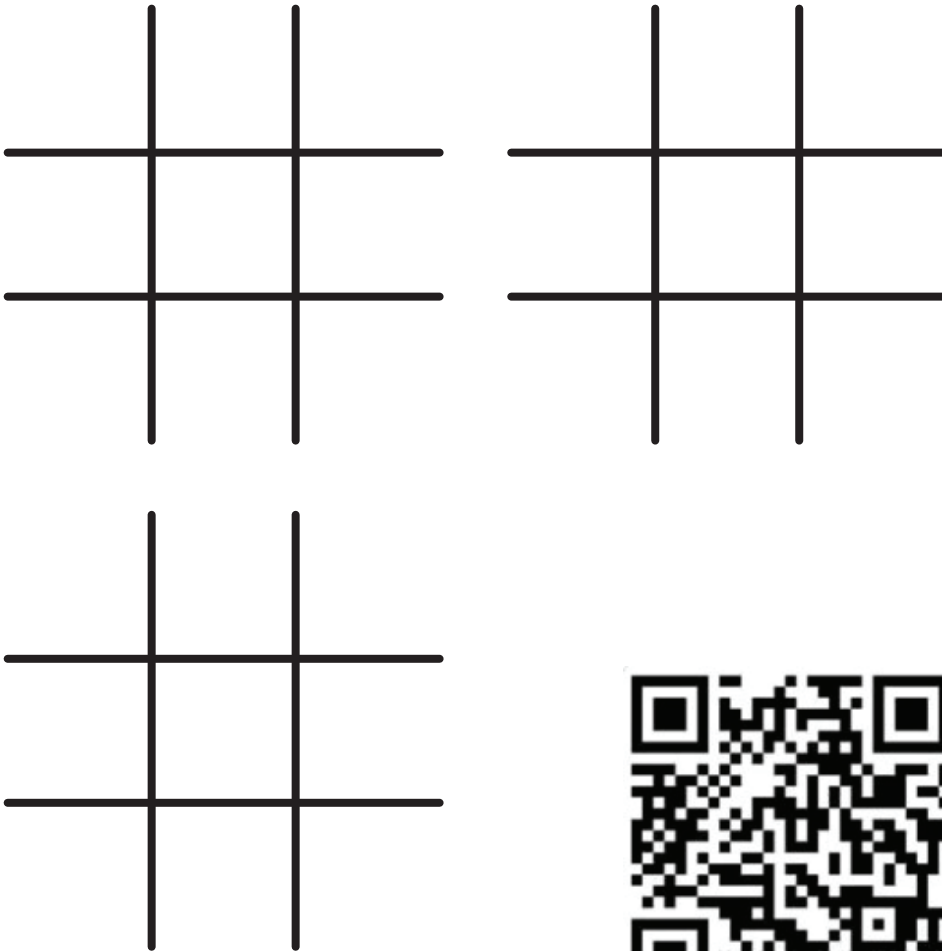

## CARTRIDGE INSTALLATION

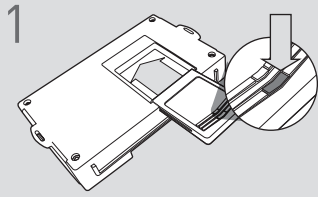

1 Slide cartridge into unit. Notice button under LED.

2

Ready for Module Programming Procedure.

## MODULE PROGRAMMING PROCEDURE

### NOTE

I To complete this procedure, use one regular key or one valet key.

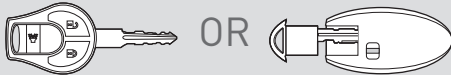

II When programming, all key fobs must be located at least 10 feet away from the vehicle.

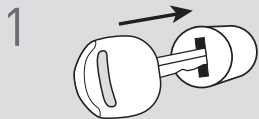
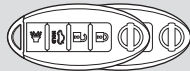

1 Insert key into ignition.

2

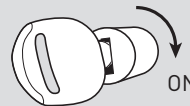

Turn key to ON position.

3

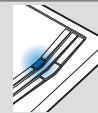

Wait, LED will turn solid BLUE for 2 seconds.

4

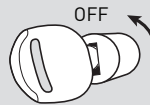

Turn key to OFF position.

5

Module Programming Procedure completed.