

Make	Model	Year	Install	CAN	Lights	RAP	Trunk	I/O Changes
DL-FM2					Park / Auto			Green White/Blue
Ford	Mustang	2010-14	Type 1	OBD-II	B			
Ford	Fusion	2006-12	Type 1	OBD-II	B			
Lincoln	MKS	2009-12	Type 1	OBD-II	B			
Lincoln	MKZ	2010-12	Type 1	OBD-II	B			
Lincoln	MKZ Hybrid	2010-12	Type 1	OBD-II	B			
Mercury	Sable	2008-09	Type 1	OBD-II	B			

Hey! Read this stuff before you start the installation...

Firmware:

Covered vehicles use **BLADE-AL(DL)-FM2**, flash module and update the controller firmware before installing.

Door Locks:

With alarm: Door locks require three wire connections (1-unlock, 2-lock) and two (2) diodes isolating the lock wires.

Mustang: Lock/Arm wire color, **yellow/gray** (pin #9/26 at BCM)

Without alarm: Door locks require two wire connections and no diodes.

Auto-lights: If vehicle is equipped with auto-light feature, refer to the diagram below for required connections.

Auto-light: **violet/green** (pin #4)

Light-off: **white/violet** (pin #6)

Okay, now get to work...

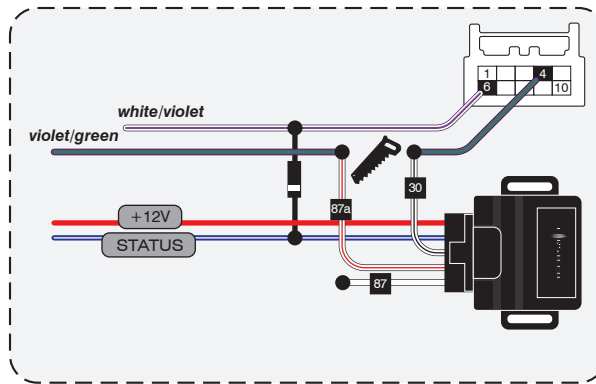

- FT-DAS Required for manual transmission.
- BOTH Red & Red/White MUST be connected with high current application.

Jumper Setting			
Parking Light	<input type="checkbox"/>	<input type="checkbox"/>	(+)Door Trigger In
Accessory	<input type="checkbox"/>	<input type="checkbox"/>	(-)Door Trigger In (Default)
Ignition (Default)	<input type="checkbox"/>	<input type="checkbox"/>	
Trunk	<input type="checkbox"/>	<input type="checkbox"/>	Starter
Starter	<input type="checkbox"/>	<input type="checkbox"/>	Ignition
Parking Light (Default)	<input type="checkbox"/>	<input type="checkbox"/>	Accessory (Default)

CM7000/7200 Cut loop for A/T

CM-900S/900AS

CM900AS/900S Jumper	
<input type="checkbox"/>	<input type="checkbox"/>
<input type="checkbox"/>	<input type="checkbox"/>
START	
ACC	
IGN1	



FTI-FDK1 Type 1B - Installation Notes & Wiring Diagram

- N** DL-FM3 TX loop, not used in this install type, do not cut.
- I** Jumper for vehicles that are not equipped with immobilizer, do not connect unless vehicle is confirmed not equipped. If vehicle is not equipped, connect before programming to skip immobilizer learn.
- C** **NO ALARM:** Door lock connection at BCM (pin #17, **blue/green**, 26-pin connector)
- K** **WITH ALARM:** Door lock/arm connections at BCM (pin #6, **yellow/green**, pin #18, **violet/green**, 26-pin connector), diode isolate the factory wires (cathode toward CM) and connect to CM output

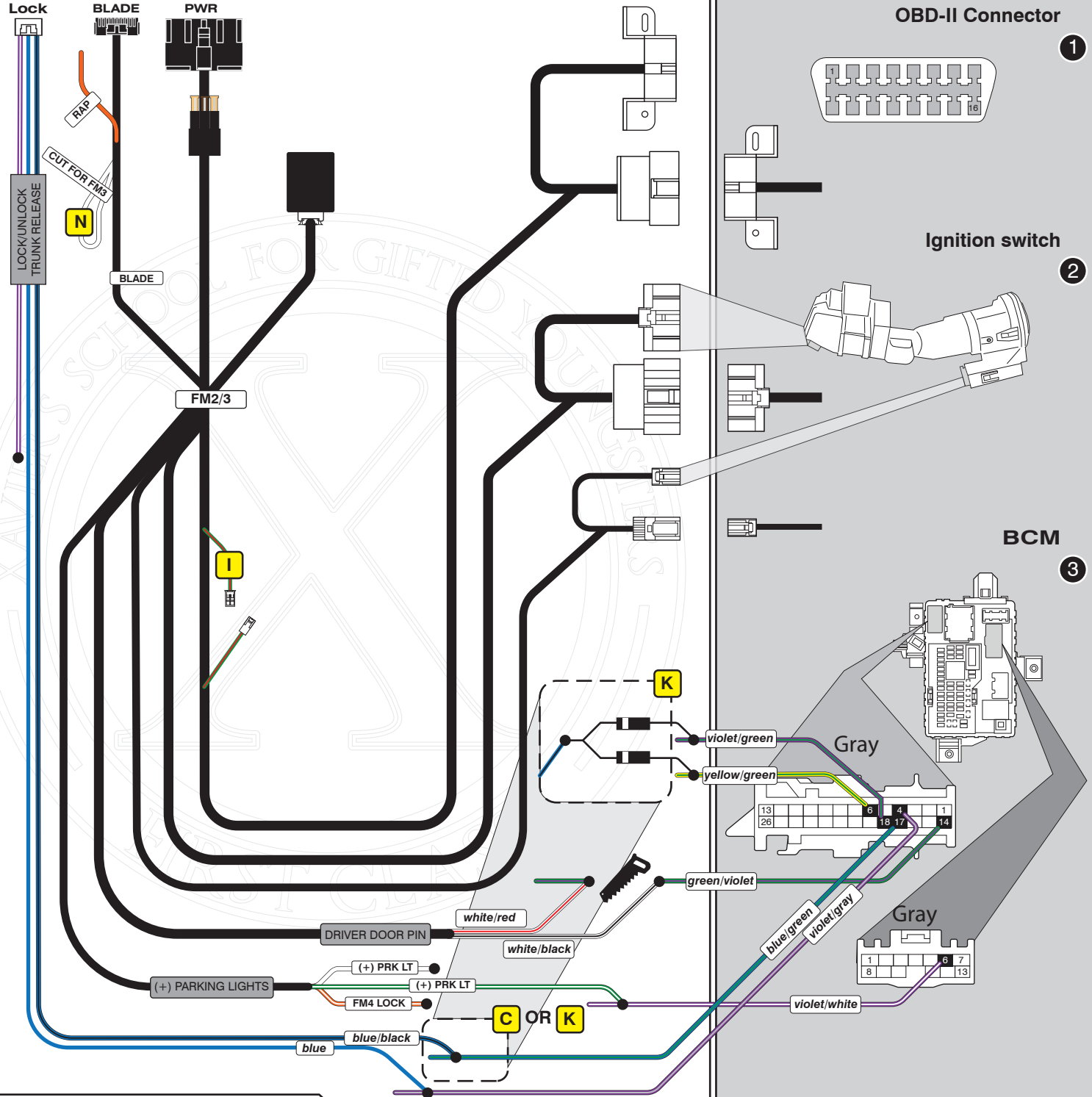

LED Programming Error Codes

Module LED flashing RED during programming

- 1x - CAN error, check wiring
- 2x - VIN error, check CAN wiring
- 3x - Wrong firmware, confirm firmware flashed
- 4x - VIN error, vehicle not identified, contact support
- 5x - Immobilizer learn error, check RX/TX wiring
- 6x - KLON error, check RX/TX wiring, confirm pin positions
- 7x - KLON error, process failed, reset module and start over
- 8x - Encryption error, confirm key encryption, 80 bit detected
- 9x - Key in cylinder, remove and proceed

Module Programming Procedure

- Step 1 - Key #1 in activate IGN, if LED goes blue, you're done if LED goes red, wait until flashes blue then key off/on
- Step 2 - If LED goes blue, you're done, if red, insert key #2 and activate IGN, when LED is red, remove key, press module button, and remote start vehicle, blue/done.

**See BLADE guide for more detailed instructions

FIRSTECH, L.L.C.

OBD-II Connector

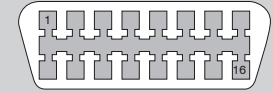

Ignition switch

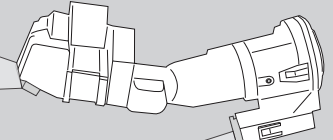

BCM

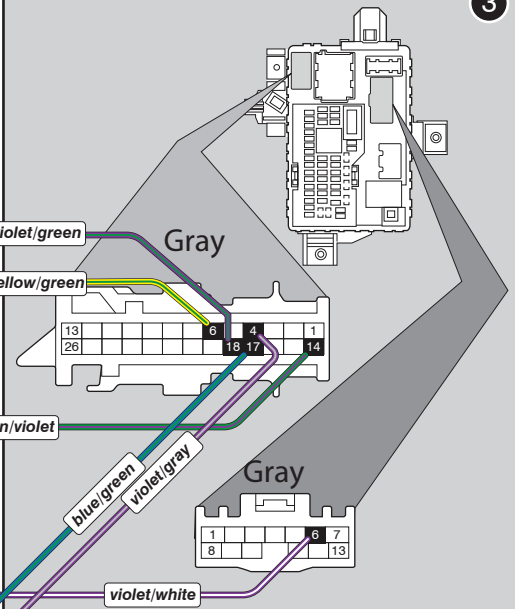

FTI-FDK1 Type 1B

SUPPORT - 1(888) 820-3690, EXT. 203