

FTI-FDK1 Type 1A2 - Vehicle Coverage & Preparation Notes

| Make | Model | Year | Install | CAN | Lights | RAP | Trunk | I/O Changes |
|---------------|--------|---------|---------|--------|--------------------|-----|-------|-------------------------|
| DL-FM2 | | | | | Park / Auto | | | Green White/Blue |
| Ford | Fusion | 2006-09 | Type 1 | OBD-II | A | | | |
| Lincoln | Zephyr | 2006 | Type 1 | OBD-II | A | | | |
| Mercury | Milan | 2006-10 | Type 1 | OBD-II | A | | | |

Hey! Read this stuff before you start the installation...

Firmware:

Covered vehicles use **BLADE-AL(DL)-FM2**, flash module and update the controller firmware before installing.

Controller Configuration:

Set feature 1-11 to option 2 (Ignition pulse - same timing as disarm pulse) for proper handling of OEM alarm.

Door Locks:

With Alarm: Door locks require three connections (1-unlock, 2-lock) and two diodes.

Without Alarm: Door locks require two wires and no diodes.

Brake:

Analog brake connection required, wire is **purple/white** (brake switch connector, pin #4).

Auto-Light Detail

Auto-Lights:

If vehicle is equipped with Auto-Light feature, refer to diagram for required connections.

Okay, now get to work...

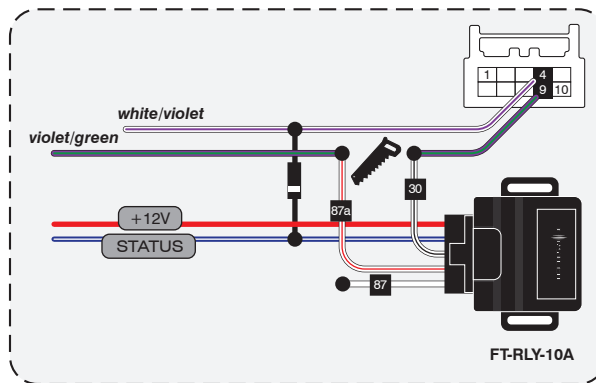

• FT-DAS Required for manual transmission.
• BOTH Red & Red/White MUST be connected with high current application.

| Jumper Setting | | | |
|-------------------------|--------------------------|--------------------------|------------------------------|
| Parking Light | <input type="checkbox"/> | <input type="checkbox"/> | (+)Door Trigger In |
| Accessory | <input type="checkbox"/> | <input type="checkbox"/> | (-)Door Trigger In (Default) |
| Ignition (Default) | <input type="checkbox"/> | <input type="checkbox"/> | |
| Trunk | <input type="checkbox"/> | <input type="checkbox"/> | Starter |
| Starter | <input type="checkbox"/> | <input type="checkbox"/> | Ignition |
| Parking Light (Default) | <input type="checkbox"/> | <input type="checkbox"/> | Accessory (Default) |

CM7000/7200 **Cut loop for A/T**

CM-900S/900AS

CM900AS/900S Jumper

START
ACC
IGN1



FTI-FDK1 Type 1A2 - Installation Notes & Wiring Diagram

- J** DL-FM3 TX loop, not used in this install type, do not cut.
- A** Jumper for vehicles that are not equipped with immobilizer, do not connect unless vehicle is confirmed not equipped. If vehicle is not equipped, connect before programming to skip immobilizer learn.
- S** **NO ALARM:** Door lock connection at BCM (pin #4, **gray/yellow**, 32-pin blue connector)
- O** **WITH ALARM:** Door lock/arm connections at BCM (pin #21, **yellow/green**, pin #16, **violet/green**, 32-pin blue connector), diode isolate the factory wires (cathode toward CM) and connect to CM output
- N** Trunk release at BCM (pin #27, **brown**, gray 32-pin connector), brake connection at the brake switch, located at the top of the brake pedal assembly (pin #4, **violet/white**)

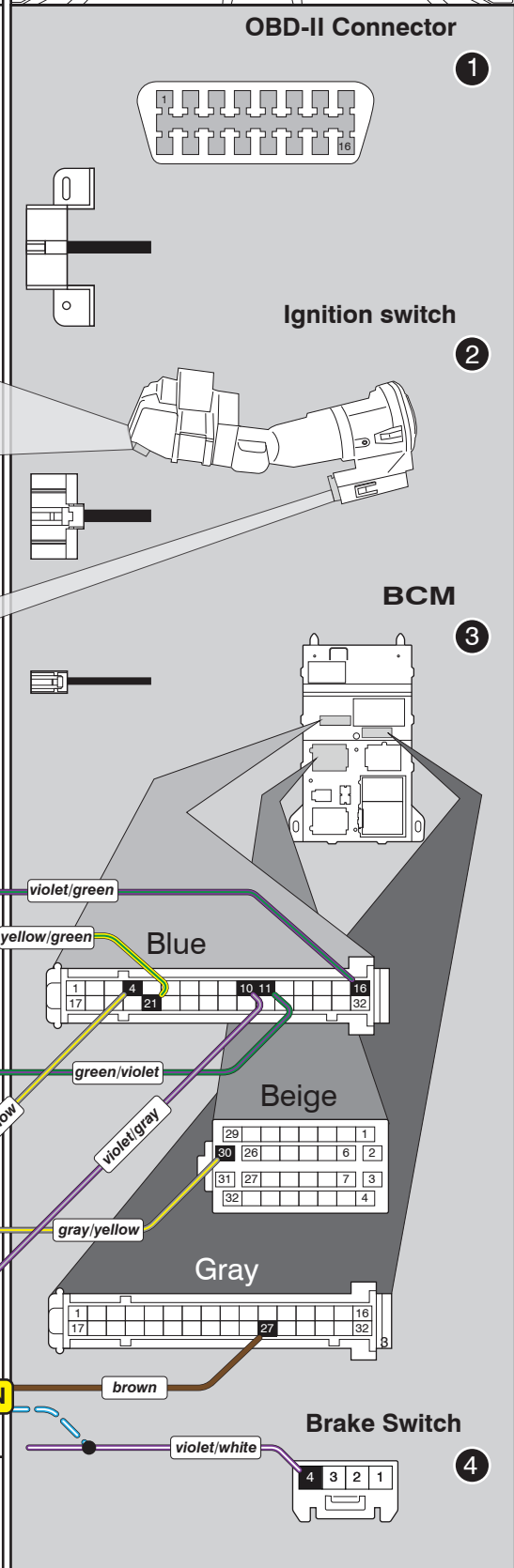
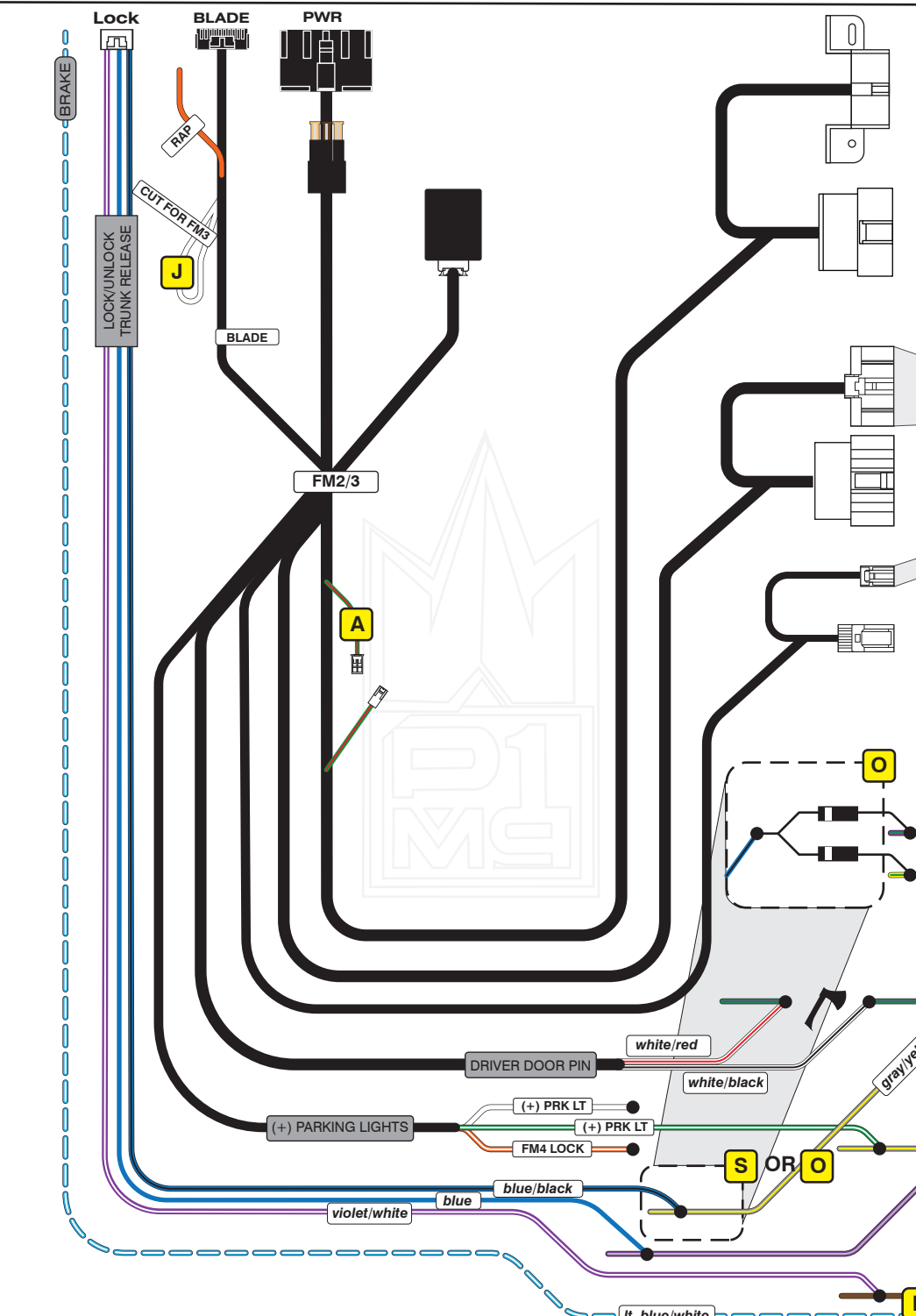
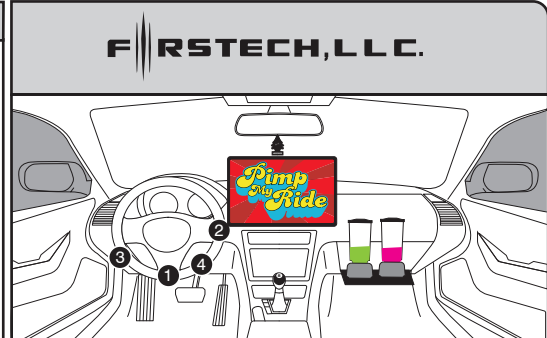

LED Programming Error Codes

Module LED flashing RED during programming

- 1x - CAN error, check wiring
- 2x - VIN error, check CAN wiring
- 3x - Wrong firmware, confirm firmware flashed
- 4x - VIN error, vehicle not identified, contact support
- 5x - Immobilizer learn error, check RX/TX wiring
- 6x - KLON error, check RX/TX wiring, confirm pin positions
- 7x - KLON error, process failed, reset module and start over
- 8x - Encryption error, confirm key encryption, 80 bit detected
- 9x - Key in cylinder, remove and proceed

Module Programming Procedure

- Step 1 - Key #1 in activate IGN, if LED goes blue, you're done if LED goes red, wait until flashes blue then key off/on
 - Step 2 - If LED goes blue, you're done, if red, insert key #2 and activate IGN, when LED is red, remove key, press module button, and remote start vehicle, blue/done.
- **See BLADE guide for more detailed instructions

FTI-FDK1 Type 1A2

SUPPORT - 1(888) 820-3690, EXT. 203